

HOW TO ORDER

PFS Rotameter

Rotameter Standard Material of Construction

Standard Rotameter with Polycarbonate Body and PVDF Float and Blockers, and EPDM O'rings

Standard: PFS-RMXXX-XXXG-PVC

Example: PFS-RM200-100G-CPVC-C-V-FS1

Rotameter
0.1 to 1 GPM capacity
1" Connection size
Union x NPT Connection type
CPVC End Caps
CPVC Union Nut
Viton O'rings
1 Magnetic Float & 1 Switch Assembly

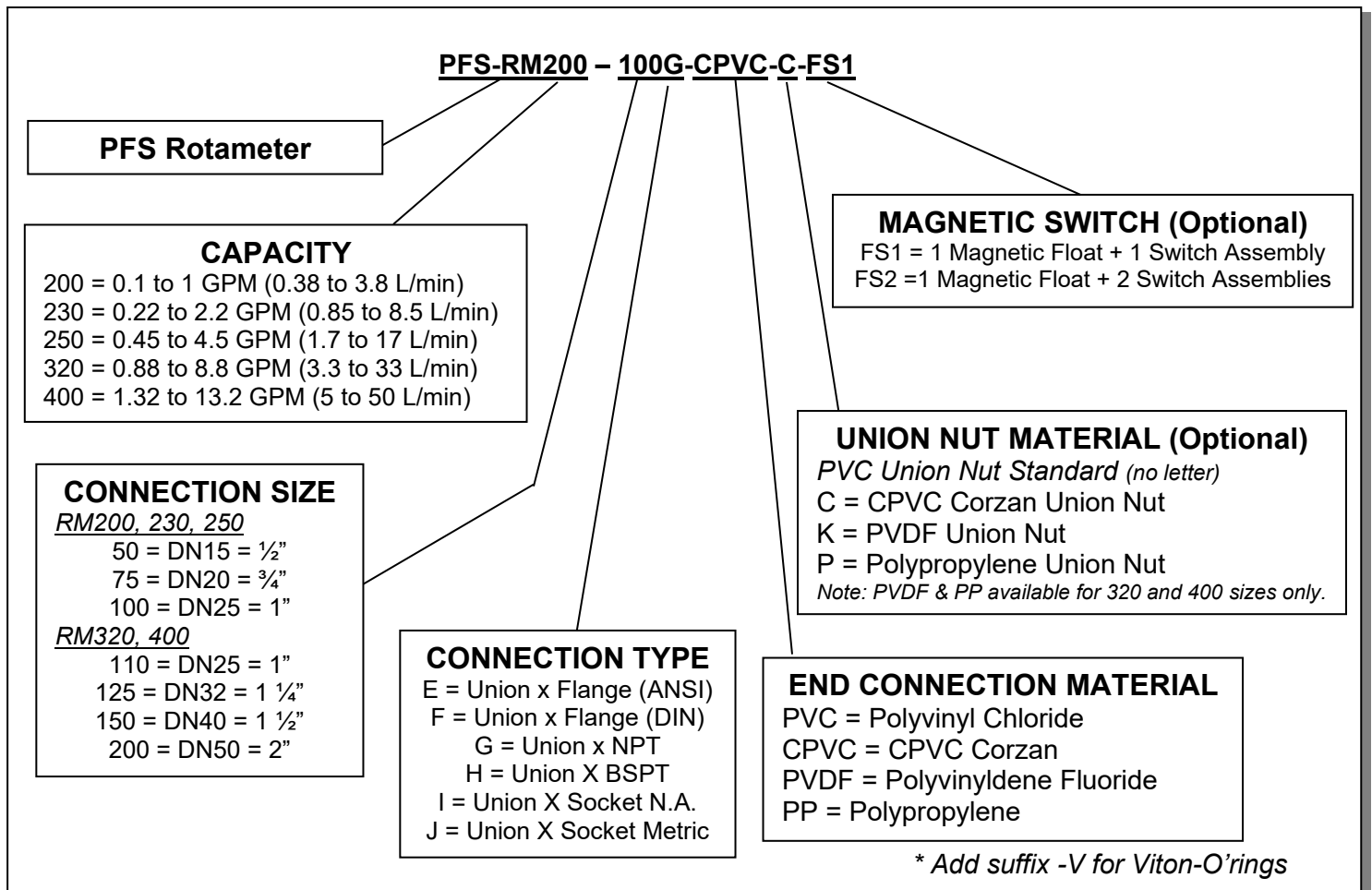

As Manufactured By:



PRIMARY FLUID SYSTEMS INC. Tel: (905) 333-8743
Fax: (905) 333-8746

North America Toll Free – 1-800-776-6580

E-Mail: primary@primaryfluid.com

<http://www.primaryfluid.com>