

THIS DRAWING IS THE PROPERTY OF PRIMARY FLUID SYSTEMS INC. FROM WHICH A WRITTEN CONSENT FOR APPROVAL SHALL BE REQUIRED PRIOR TO COPYING.

	NO.	NAME	DESCRIPTION
	1	MAX ALLOWABLE OPERATING TEMPERATURE	140°F (60°C)
	2	MAX ALLOWABLE OPERATING PRESSURE	15 PSIG
CONNECTIONS	3	BOTTOM PORT CONNECTION	2"
	4	TOP PORT CONNECTION	OPEN
	5	TYPE	FLANGE
MATERIALS	6	CYLINDER	CLEAR PVC
	7	END CAP	PVC
	8	FLANGE, ANSI B16.5	PVC
	9	GLUE	CPVC, CHEMICAL RESISTANT
INPUT DATA	10	VOLUME SIZE	15000 ML / 240 GPH
SCALE	11	BI DIRECTIONAL GRADUATIONS	200 ML / 2 GPH DIVISIONS
	12	ALL CYLINDERS ARE RATED FOR LIQUID SERVICE ONLY	√
COMMENTS	13	CYLINDERS ARE NOT PRESSURE VESSELS	√
		NSF 61 APPROVED	

CLEARVIEW®
CV#1 PVC CALIBRATION CYLINDER

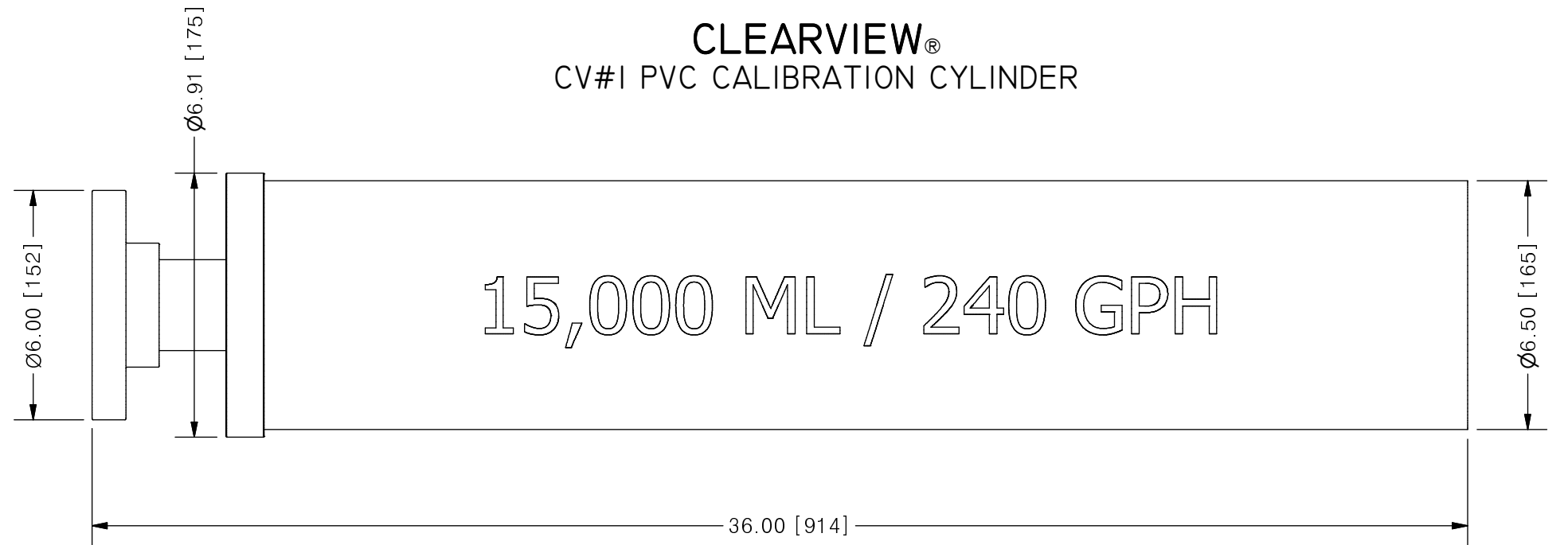
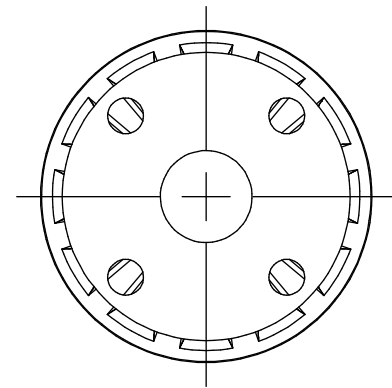

SCALE 1 : 4

0	NEW DRAWING	--	--
REV	DESCRIPTION	DATE	NAME
REVISION HISTORY			

PRIMARY FLUID SYSTEMS INC. 1050 COOKE BLVD, BURLINGTON, ONTARIO L7T 4A8		PROJECT: CV	SHT: 1 OF 1	DRAWN BY: BRJB
TITLE: 15000 ML CALIBRATION CYLINDER WITH 2" FLANGE CONNECTION		DATE DRAWN: 6/20/2017	SCALE: 1 : 4	UNITS: INCH [mm]
DWG NAME: CV CYLINDER DWG TYPE: PLANAR VIEW		MATERIAL: SEE CHART	DWG NO: CV#1-15000-F_R0	REV# 0
APPROVED BY: _____ CHECKED BY: _____		DIMENSIONAL TOLERANCE 0.X = ± 0.25" 0.XX = ± 0.25" 0.XXX = ± 0.25"		SHEET SIZE: B